



A Brand of The Fredericks Company

## Application Note 3000 MX Series Replacement of MP Series Active Gauges

### Description

The MX series of active gauges was designed as a direct replacement for the MP series of active gauges. This document describes how an MX can be used to replace an MP. Note that the MX series provides significant benefits over the MP series in performance, price, and appearance.

### General Comparison Chart

The following chart compares the general features of the MX2A, MX4A, MP2AR, and MP4AR:

Feature	MX2A	MX4A	MP2AR	MP4AR
Range	$1 \times 10^{-4}$ to 1000 Torr	$1 \times 10^{-4}$ to 1000 Torr	$1 \times 10^{-3}$ to 20 Torr	$1 \times 10^{-3}$ to 1000 Torr
Orientation	Any ( $1 \times 10^{-4}$ to 20 Torr) Vertical (20 to 1000 Torr)	Vertical	Any	Vertical
Cost (1 lowest, 4 highest)	1	2	3	4
Analog Outputs	7 user selectable	7 user selectable	2 factory set	3 factory set
Communications	RS-485	RS-485	None	None
Response Time	< 2 seconds	< 1 second	< 2 seconds	< 1 second
Accuracy (1 best, 4 worst)	2	1	4	3

### Analog Outputs

An MP includes up to **three** options for analog output behavior, they are the following:

1. Log
2. Linear
3. Non-linear

An MX includes **seven** options for analog output behavior, they are the following:

1. Log
2. Linear 1
3. Linear 2
4. Linear 3
5. Linear 4
6. Linear by decade
7. Non-linear

The relationships between the analog outputs of the MP and MX:

MP2AR Output	MX2A Equivalent Output
Linear	Linear 4
Non-linear	None

MP4AR Output	MX4A Equivalent Output
Log	Log
Linear	Linear 4
Non-linear	Non-linear

On an MP, the analog output behavior is chosen by jumpers and pin selection. This process is considerably simplified on an MX and can be done using the front panel or through RS-485 communications. Here is an example showing how you could switch the output of an MX to **Linear 4** in order to match the **Linear** output of an MP:

1. Navigate to the Measurement Screen
2. Press SEL four times, the screen will read "Analog Out"
3. Press ENT to unlock the screen
4. Press DOWN three times, the screen will read "Linear 4"
5. Press ENT to save the change

### Wiring Connections

MP and MX connector comparison:

MP Connector	MX Connector
D-sub 9 pin	D-sub 15 pin

Power connections:

Connection	MP Pin	MX Equivalent Pin
Power (+)	Pin 3	Pin 8
Power (-)	Pin 4	Pin 15

Analog output connections:

Connection	MP Pin	MX Equivalent Pin
Log/Linear Analog Output (+)	Pin 5	Pin 9
Non-linear Analog Output (+)	Pin 7	Pin 9
Analog Output (-)	Pin 8	Pin 1

Set point connections:

Connection	MP Pin	MX Equivalent Pin
Set Point Relay NO	Pin 1	Pin 4
Set Point Relay NC	Pin 2	Pin 3
Set Point Relay C	Pin 6	Pin 11

Overall pin diagram comparison:

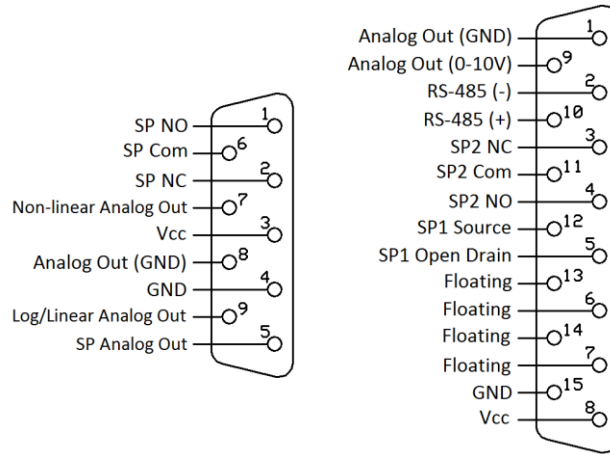

## Calibration

Calibration points on an MP are adjusted using pots. Calibration points on an MX are adjusted using the front panel or RS-485 communications.

### MP2AR and MX2A Calibration Points

Calibration Point	MP2AR	MX2A
Zero	Yes	Yes
10 Torr	No	Yes
760 Torr (Atmosphere)	No	Yes

### MP4AR and MX4A Calibration Points

Calibration Point	MP4AR	MX4A
Zero	Yes	Yes
1 Torr	No	Yes
70 Torr	No	Yes
760 Torr (Atmosphere)	Yes	Yes

Additional calibration points on an MX allow for more accurate measurements than an MP.

## Display

There are a variety of differences between the displays of an MP and an MX:

Description	MP Display	MX Display
Type	3 character 7-segment LED	256x64 color OLED
Location	Top	Front
Readable Distance	3 m (10 feet)	3 m (10 feet)

The higher display resolution on an MX allows access to features through the front panel. This is not possible on an MP.

### Set Points

An MX includes two set points while an MP only has one. Additionally, the ratings on MX set points are much higher than the ratings on an MP set point:

Description	MP	MX
Set Points	1	2
Type	Relay	Relay, Open Collector
Relay Contact Rating	0.5 A @ 24 VDC	2 A @ 220 VDC (250 VAC)
Open Collector Rating	None	2 A @ 60 VDC

### MX Series Additional Benefits

Many modern systems incorporate digital communications for increased accuracy and ease of use. While an MP does not include any digital communications, an MX comes standard with RS-485 communications. RS-485 is addressable allowing multiple MX units to be connected to the same bus, reducing wiring requirements. Additionally it provides the ability to remotely adjust features of an MX without requiring access to the front panel.

### Contact Us

If you have any questions, please feel free to contact us:

The Fredericks Company - Televac  
2400 Philmont Avenue  
Huntingdon Valley, PA 19004  
Web: [www.frederickscompany.com](http://www.frederickscompany.com)  
Email: [sales@frederickscompany.com](mailto:sales@frederickscompany.com)  
Phone: +1 215 947 2500