



FREDERICKS COMPANY

High Performance Sensing Solutions™

Dual Axis Tilt Switch with Relay Output Instruction Manual Rev K



©2021 - The Fredericks Company
2400 Philmont Avenue
Huntingdon Valley, PA 19006

www.frederickscompany.com
+1 215 947 2500

Table of Contents

- 1. Product Information..... 3**
 - 1.1 Description 3
 - 1.2 Specifications 3
 - 1.3 Physical Specifications..... 4
 - 1.4 Part Numbers 4
 - 1.5 Related Products 5
- 2. Installation 5**
 - 2.1 Direction of Measurement 5
 - 2.2 Mounting..... 5
 - 2.3 Electrical Connections 5
 - 2.4 RS-232 Settings..... 6
- 3. Reading the Tilt Switch..... 6**
 - 3.1 Relays 6
 - 3.2 RS-232 7
- 4. Configuration 8**
 - 4.1 Zeroing the Tilt Switch..... 8
 - 4.2 Setting Trip Points 8
 - 4.3 Set Filter Values..... 9
 - 4.4 Set Trip Delay 9
 - 4.5 Set Return Delay..... 9
 - 4.6 Set Polarity 9
 - 4.7 Set Hysteresis 10
 - 4.8 Set Baud Rate 10
 - 4.9 Save Settings to ROM 10
 - 4.10 Flashing with the Bootloader 10
- 5. Command Reference..... 11**
 - 5.1 Sensor Data 11
 - 5.2 Configuration..... 11
 - 5.3 Product Information..... 11

1. Product Information

1.1 Description

- 1.1.1 The 0729-1763-XX RS-232 programmable tilt switch utilizes Fredericks TrueTilt™ wide range, mid-range, or narrow range electrolytic tilt sensors and four output relays with user-settable trip points. Its robust plastic housing and epoxy potting provide excellent durability and environmental protection. This tilt switch has superior tolerances and unit to unit performance. Its small profile and economic design make it an ideal solution for a versatile range of applications in all sectors.

The tilt switch has been designed with the ability to be programmed via an RS-232 link to be adaptable for many applications. The features can be preset by the factory to customer specifications or by the user. With one basic model all features can be preset such as - set trip angles, set zero position, set trip/return delay, set polarity of relay (normally on or off), set hysteresis (return from trip point angle) and set filter value (eliminate vibrations). These values will be permanently saved to internal memory. The unit also has a bootloader for potential updates and software modifications while in the field should they be desired or necessary.

- 1.1.2 For more than 85 years Fredericks has been a global provider and U.S. manufacturer of high-performance tilt measurement products. Built to last, our products are made with state-of-the-art sensing technology, proven processes, and an intrinsic passion for the trade. Offering simple integration and quality and safety benchmarks, our customers benefit not just from standard-setting reliability, but from our commitment to competitive pricing and performance. For more information, visit our website at www.frederickscompany.com.

1.2 Specifications

| | Wide Range | Mid-Range | Narrow Range |
|--------------------------------------|---|-----------|--------------|
| Communications | RS-232 communications and relay outputs | | |
| Supply Voltage | 6.5 V DC to 40 V DC | | |
| Supply Current | 30 mA @ 12 V DC | | |
| Operating Range | ±45° | ±25° | ±10° |
| Linear Range | ±25° | ±10° | |
| Repeatability | ±0.1° | ±0.005° | ±0.1° |
| Resolution | ≤0.003° | ≤0.0002° | ≤0.003° |
| Axes | 2 | | |
| Null Offset | ≤5° | | |
| Cross Axis (Roll) Sensitivity | ≤0.025° per degree | | |
| Long Term Stability/Drift | ≤0.1° per degree | | |
| Null Temperature Offset | ≤0.006° per °C | | |
| Scale Temperature Offset | 0.1% per °C | | |
| Operating Temperature | -40 °C to 70 °C | | |
| Storage Temperature | -40 °C to 125 °C | | |
| Time Constant | ≤100 ms | | |
| IP Rating | IP66 | | |

1.3 Physical Specifications

| | |
|----------------------|-------------------|
| Housing | ABS Plastic |
| Length | 79.76 mm (3.14") |
| Width | 53.34 mm (2.10") |
| Height | 27.31 mm (1.08") |
| Cable Length | 45.7 cm (18") |
| Hole Center | 91.22 mm (3.59") |
| Hold Diameter | 5 mm (0.19") |
| Weight | 82 g (non-potted) |

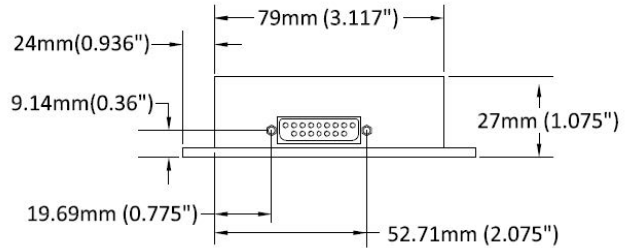
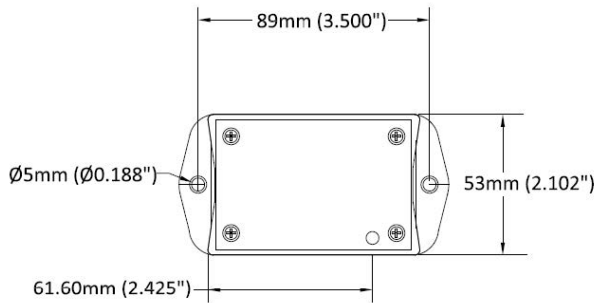

1.4 Part Numbers

1.4.1 Housing

| Description | Part Number |
|---|--------------|
| Tilt Switch with Plastic Housing (Potted) | 0729-1763-01 |
| Tilt Switch with Plastic Housing (Not Potted) | 0729-1763-03 |

1.4.2 Sensor

| Description | Part Number |
|--------------|-----------------------------------|
| Wide Range | 0717-4318-99 |
| Mid-Range | 0703-1602-99 (x2) |
| Narrow Range | 0717-4319-99 |

1.4.3 Cable

| Description | Part Number |
|--------------|-------------|
| 10 ft (3 m) | 2-9858-010 |
| 20 ft (6 m) | 2-9858-020 |
| 35 ft (10 m) | 2-9858-035 |
| 50 ft (15 m) | 2-9858-050 |

1.5 Related Products

| Description | Part Number |
|--|------------------------------|
| ±35° Range, ±0.1° Repeatability Tilt Switch (Relay) | 0729-1736-99 |
| ±45° Range, ±0.1° Repeatability Tilt Switch (Open Collector) | 0729-1757-99 |
| ±45° Range, ±0.1° Repeatability Tilt Switch (Open Collector) | 0729-1758-99 |

Visit us online at www.frederickscompany.com to see our entire collection of tilt switches and inclinometers.

2. Installation

2.1 Direction of Measurement

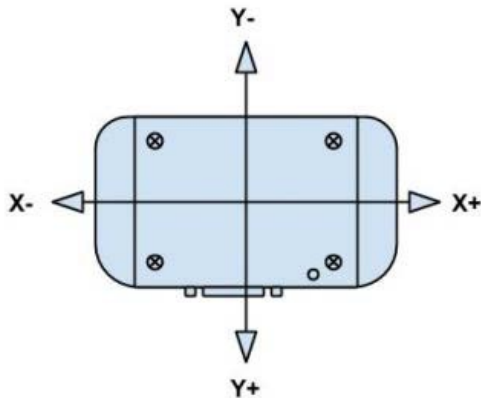

2.2 Mounting

- 2.2.1 The tilt switch must be mounted horizontally (parallel to the surface of the earth and perpendicular to the force of gravity). For best performance, mount the unit somewhere it will be isolated from vibrations.

2.3 Electrical Connections

| Pin Number | Color | Description |
|------------|--------|-----------------|
| 1 | Red | Ground |
| 2 | White | Relay 1 (NO/NC) |
| 3 | Green | Relay 2 (NO/NC) |
| 4 | Yellow | Relay 3 (NO/NC) |
| 5 | Blue | Relay 4 (NO/NC) |
| 6 | Brown | RS-232 Tx |
| 7 | Orange | Zero Wire |
| 8 | Red | V _{DD} |
| 9 | Black | Ground |
| 10 | Black | Relay 1 (COM) |
| 11 | Black | Relay 2 (COM) |
| 12 | Black | Relay 3 (COM) |
| 13 | Black | Relay 4 (COM) |
| 14 | Black | RS-232 Rx |
| 15 | Black | Ground |

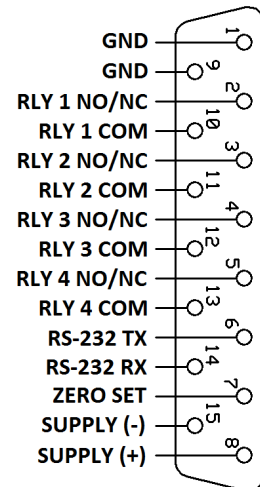

2.4 Zero Wire – READ THIS BEFORE USE

- 2.4.1 During normal operation, the zero wire for the switch **must** be connected to ground. If this is not properly connected when the switch is turned on, the switch will not start. To fix this, disconnect the power, ground the zero wire, and reconnect power. If the zero wire is disconnected from ground while the switch is operating, the zero angle will be set to the current angle. To fix this, follow the procedure described in section 4.1.1.

2.5 RS-232 Settings

| | |
|------------------|-------------------------|
| Baud Rate | 9600 (default, see 4.8) |
| Data Bits | 8 |
| Parity | None |
| Stop Bits | 1 |

3. Reading the Tilt Switch

3.1 Relays

- 3.1.1 A relay has 3 connections: COM (COMmon), NC (Normally Closed), and NO (Normally Open). In its normal state, COM is connected to NC, and NO is left open. In its switched state, NO is connected to COM and NC is open. These states are shown below:

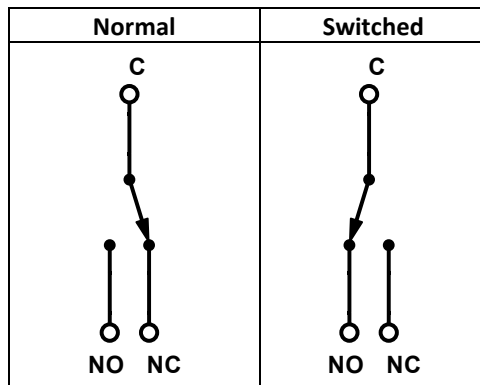

- 3.1.2 The 0729-1763-XX uses relays with 2 connections, COM and NC/NO. The function will depend on the polarity. When polarity is 0, the NC/NO connection functions as the NC connection. When polarity is 1, the NC/NO connection functions as the NO connection. This function is shown below:

| | Polarity = 0 (default) | Polarity = 1 |
|-------------------|-------------------------------|---------------------|
| Un-tripped | Closed | Open |
| Tripped | Open | Closed |

- 3.1.3 Four relays are available to read the trip status: x positive, x negative, y positive, and y negative. Each relay has its own COM connection that can be connected independently. The polarity setting will apply to all 4 relays.

3.2 RS-232

3.2.1 Trip Points

3.2.1.1 All trip points with their status can be viewed using the 6 command. Below is an example of the output:

```
Current Trip Points:  
Positive X-axis = 5.0  
Negative X-axis = -5.0  
Positive Y-axis = 5.0  
Negative Y-axis = -5.0  
Current relays ('1' indicates a trip):  
Positive X-axis = 1  
Negative X-axis = 0  
Positive Y-axis = 0  
Negative Y-axis = 0
```

3.2.1.2 The statuses of the trip points will be displayed with the 8 command. The values will be in the same order as above. The following example shows this output, assuming the same status as the previous example:

```
1  
0  
0  
0
```

3.2.1.3 Individual trip points can be checked with the following commands:

| Description | Command |
|-------------|---------|
| Positive X | j |
| Negative X | k |
| Positive Y | l |
| Negative Y | m |

3.2.2 Tilt Angle

3.2.2.1 The raw linear tilt angle can be read using the x and y commands. This will return a raw 16-bit value representing the tilt within the linear range of the sensor. For example, if the linear range is $\pm 10^\circ$, 0 would represent -10° and 65535 would represent 10° .

3.2.2.2 The raw nonlinear tilt angle can be read using the a (x axis) and b (y axis) commands. This will return a raw 16-bit value representing the tilt within the operating range of the sensor. This value will not be linear and requires additional calculations to convert into a tilt angle.

3.2.2.3 The angle can be read in degrees using the c (x axis) and d (y axis) commands. The return value will have precision of 2 significant digits after the decimal point.

3.2.3 Temperature

3.2.3.1 The temperature sensor can be read using the t command. This will return the temperature in $^\circ\text{C}$ as an integer.

4. Configuration

4.1 Zeroing the Tilt Switch

4.1.1 Using the Zero Wire

- 4.1.1.1 Mount the switch, ensuring the system is level. Note that the switch must be within 5° of level to properly zero the internal sensor.
- 4.1.1.2 Ground the zero wire (pin 7), then supply power to the switch.
- 4.1.1.3 Disconnect the zero wire from ground; the LED should turn on.
- 4.1.1.4 After 4 seconds, reconnect the zero wire to ground. Note that this operation will time out after 12 seconds.
- 4.1.1.5 If the zeroing is successful, the LED will blink 3 times.

4.1.2 Using RS-232

- 4.1.2.1 Mount the switch, ensuring the system is level. Note that the switch must be within 5° of level to properly zero the internal sensor.
- 4.1.2.2 Supply power to the sensor and connect to the RS-232 port.
- 4.1.2.3 Send the n command over RS-232 to center the switch to the current angle.

4.2 Setting Trip Points

- 4.2.1 Trip points must be set RS-232. Commands are available to set independent trip points in each direction and each axis. The commands to set the trip point are shown below:

| | |
|----------|------------|
| 1 | Positive X |
| 2 | Negative X |
| 3 | Positive Y |
| 4 | Negative Y |

- 4.2.2 To set a trip point, send one of the commands above. Then, enter the desired trip angle in XX.X format.
- 4.2.3 For negative trip points, the trip angle should be in the -XX.X. Without the “-”, the trip point will not be set properly.
- 4.2.4 For example, to set the positive Y trip angle to 3°, enter the command 303.0. To set the negative X trip angle to 3°, enter the command 2-03.0.

4.3 Set Filter Values

- 4.3.1 The filter value will determine how many tilt samples will be used to determine the current angle. For example, a filter value of 20 (default) will mean the last 20 tilt measurements will be averaged together before checking the trip angle. Higher filter values will use more samples, reducing output noise from things like vibration, but will be less responsive.
- 4.3.2 The filter value is set with the + and – commands. + will increase the filter by 1, up to 255. – will decrease the filter value by 1, down to 1. The output is shown below:

Filter value: 20

4.4 Set Trip Delay

- 4.4.1 Trip delay is the amount of time the sensor must tilt past the trip angle before it will trip the switch. By default, this is 0.5 seconds.
- 4.4.2 To set the trip delay, enter the e command, followed by a number from 0 to 9. The trip delay will be the number entered times 0.5 seconds.
- 4.4.3 For example, to set the trip delay to 1.5 seconds, enter e3.

4.5 Set Return Delay

- 4.5.1 Return delay is the amount of time the sensor must tilt back within the trip angle before it will un-trip the switch. By default, this is 0 seconds.
- 4.5.2 To set the return delay, enter the f command, followed by a number from 0 to 9. The return delay will be the number entered times 0.5 seconds.
- 4.5.3 For example, to set the return delay to 2.5 seconds, enter f5.

4.6 Set Polarity

- 4.6.1 The polarity setting controls the relay output polarity from the sensor. The relay behavior is shown in the table below:

| | Polarity = 0 (default) | Polarity = 1 |
|------------|------------------------|--------------|
| Un-tripped | Closed | Open |
| Tripped | Open | Closed |

- 4.6.2 To set the polarity, enter the g command, followed by 0 or 1.
- 4.6.3 For example, to set the polarity to 1, enter g1.

4.7 Set Hysteresis

- 4.7.1 Hysteresis is the distance past the trip angle the sensor must return to un-trip the sensor. This is done to prevent oscillations in the switch's output.
- 4.7.2 For example, say the trip angle is 10°, and the hysteresis angle is 1°. When the switch tilts to 11°, the switch is tripped. If it moves back to 9.5°, the switch will stay tripped because it is still within the hysteresis angle. Tilting the switch past 9° will un-trip the switch.
- 4.7.3 To set the hysteresis angle, enter the h command, followed by a number from 1 to 8. The hysteresis angle will be the number entered times 0.25°.
- 4.7.4 For example, to set the hysteresis angle to 0.75°, enter the command h3.

4.8 Set Baud Rate

- 4.8.1 To set the baud rate, enter the s command, followed by the code for the baud rate desired. The codes are shown below:

| | |
|---|--------|
| 1 | 9600 |
| 2 | 19200 |
| 3 | 38400 |
| 4 | 57600 |
| 5 | 115200 |

- 4.8.2 For example, to set the baud rate to 38400, enter the command s3.

4.9 Save Settings to ROM

- 4.9.1 Settings will normally be saved to RAM, and will be lost when the switch loses power. To save the configuration to persistent memory, use the 5 command to save the settings to ROM.

4.10 Flashing with the Bootloader

- 4.10.1 With the switch powered down, connect the RS-232 port to a computer and open a serial monitor.
- 4.10.2 Ensure the zero wire is **floating**, then supply power to the switch.
- 4.10.3 The RS-232 terminal should display the following text:

```
Bootloader Version 1.0  
Waiting for download...
```

If this does not appear, repeat steps 1 and 2.

- 4.10.4 Execute the firmware update file.
- 4.10.5 Once the file download is complete, disconnect power to shut down the switch.
- 4.10.6 The switch has now been reprogrammed. Make sure to reconnect the zero wire to ground prior to using the switch in your system.

5. Command Reference

5.1 Sensor Data

| Description | Command | Example Output |
|--|----------|--------------------------------|
| Raw X axis tilt (linear) | x | 43215 |
| Raw Y axis tilt (linear) | y | 25743 |
| Raw X axis tilt (non-linear) | a | 38643 |
| Raw Y axis tilt (non-linear) | b | 27452 |
| X axis tilt in degrees | c | 12.53 |
| Y axis tilt in degrees | d | -21.42 |
| Current temperature | T | 25 |
| Display trip points and tripped relays | 6 | See 3.2.1.1 |
| Display relay statuses | 8 | See 3.2.1.2 |
| Positive X Trip Point Status | j | 1 if tripped, 0 if not tripped |
| Negative X Trip Point Status | k | 1 if tripped, 0 if not tripped |
| Positive Y Trip Point Status | l | 1 if tripped, 0 if not tripped |
| Negative Y Trip Point Status | m | 1 if tripped, 0 if not tripped |

5.2 Configuration

| Description | Command | Comments |
|--------------------------------|---------------|---|
| Set current position as zero | n | |
| Reset zero | z | Reset zero to mechanical zero |
| Set positive X axis trip angle | 1XX.X | XX.X is the trip point in degrees |
| Set negative X axis trip angle | 2-XX.X | XX.X is the trip point in degrees |
| Set positive Y axis trip angle | 3XX.X | XX.X is the trip point in degrees |
| Set negative Y axis trip angle | 4-XX.X | XX.X is the trip point in degrees |
| Increment the filter | + | Maximum 255 |
| Decrement the filter | - | Minimum 1 |
| Set trip delay | eX | X is 0 to 9. Set to 0.5 * X |
| Set return delay | fX | X is 0 to 9. Set to 0.5 * X |
| Set polarity | gX | X is 0 or 1 |
| Set hysteresis | hX | X is 1 to 8. Set to 0.25 * X |
| Set baud rate | s | Keys to set baud rate will be displayed. |
| Save configuration to ROM | 5 | Prevents configuration from being lost on power off |

5.3 Product Information

| Description | Command | Comments |
|---------------------------|----------|--|
| Product information | v | |
| Configuration information | 9 | Displays trip points, range, trip delay, return delay, polarity, hysteresis, and baud rate |
| Show all commands | ? | |